

LEINE  LINDE



PREMIUM 900 SERIES

ABSOLUTE ENCODERS FOR HEAVY DUTY INDUSTRIES



Premium performance

Leine Linde has long been known for encoders made for heavy duty applications. The Premium 900 series is the starting point in the experience for such applications, and the rise to a new level when it comes to functionality.

Functionality

Machines are becoming more and more advanced in classic industrial applications. More complex motions need to be monitored in order to achieve full process control. To meet this increasing demand the 900 series is based on absolute scanning which enables position feedback with high resolution. It is available with different types of interfaces for transfer of detailed data into the required system.

Reliability

With rising demands on machine efficiency the reliability of each component is critical. The 900 series therefore offers increased performance when it comes to enduring conditions like high temperatures and moisture or vibration and shock. All to achieve a reliable motion feedback at all times.

Flexibility

Flexibility when it comes to interfaces is important in order to provide an encoder for easy integration in the machine, and therefore the 900 series offers a variety of different shafts, connectors and communication interfaces. Backed up with fast delivery times and local technical support Leine Linde is there to help you to solve your needs.

Absolute confiden

How does one design a Premium encoder line? The development of the 900 series focused on the following five areas in order to provide a user-friendly encoder made to endure.

1. Lifetime – reliability year after year

The most important factor when it comes to encoder lifetime is the size of the bearings. They will rotate millions of revolutions during many years in operation. By using bearings twice the size compared to similar encoders on the market, the 900 series is made to serve a long life in operation. Reliability is to know that the encoder will do its job, always.

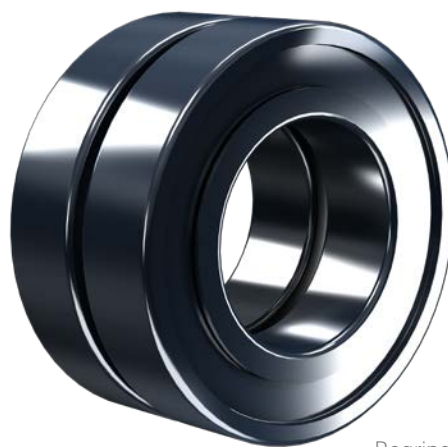

Bearings scale 1:1

2. Temperature and moisture

– full performance in all environments

The 900 series is designed to perform in the most demanding environments. Some encoders end up in outdoor applications where they must withstand intense cold during the winter, while others are installed in metal processing applications where they are exposed to extreme heat. Moisture is another climate factor, whether it be rain and snow or hot water and steam. In some applications the encoder is exposed to dramatic fluctuations where the temperature may change in seconds.

Withstanding this is a matter of details and caring for each component of the encoder. The mechanics are

produced with strict demands on tolerances to offer a perfect fit. The cover is treated with an anodization to keep a smooth surface also when exposed to salt water. The shaft sealings are specified to at least IP66 even after years in operation. The bearings are selected with a grease that withstands temperatures well above the limits of the encoder. Care is given when selecting each specific electronic component to be sure it fulfills the stringent requirements. When the full design is put together it is tested to its limits, in order to be sure that everything performs together. Once again it's about reliability – to know that it will work even at exceptional conditions.

3. Vibration and shock – designed to endure

Market standard encoders have their most sensitive point in the optical scanning components for detection of shaft position. This may be a problem in heavy duty applications like metal processing where an encoder is subject to high continuous vibrations and instant shocks. Thanks to the inductive scanning

principle a solution with top-notch robustness without compromising on resolution and accuracy is achieved. The 900 series is based on components which are extra resistant to harsh treatment and provides a solution where robustness is in its essence. At the same time it offers a high resolution output of 19 bit singleturn and 16 bit multiturn.



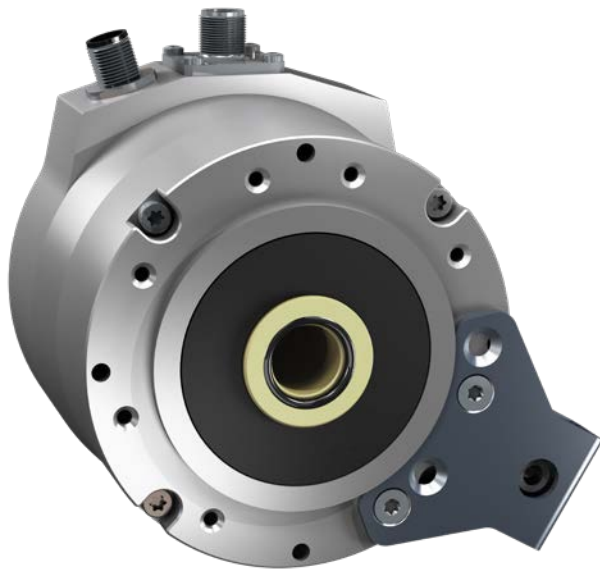

4. Flexibility in design – easy to integrate

To fit the machine, a big variety of interfaces, both mechanical and electrical, are provided.

To suit different shaft sizes, the 900 series offers both hollow shafts and solid shafts in several different dimensions and with special features such as taper shaft, keyway or key nut.

Leine Linde offers interfaces for electronic integration, whether it is serial, over a fieldbus or as incremental pulses. If required, combinations of absolute and incremental outputs from the same unit are possible.

5. Installation – handling the encoder

Thanks to the compactness of the inductive scanning, the bearings are twice the size compared to similar heavy duty encoders on the market. All without increasing the total size of the encoder. This will make the 900 series fit, without having to redesign the installation where another heavy duty encoder has been used.

The 900 series is available with connectors or pre-mounted cables. Or, if preferred, cable glands for terminal connection on site – easily accessed on the back of the encoder and with the encoder's internal parts always enclosed by a protection cover. For more information, see code keys on page 12-13.



Mechanics

– solutions for easy installation

The 900 series features a heavy duty design with connection through cable glands, M12 or M23 connectors. These pages show an overview of the different mechanical variants available in the 900 series. Other variants can be created according to the code key on pages 12-13.

Absolute encoders

Hollow shaft with 2 x M12 connectors

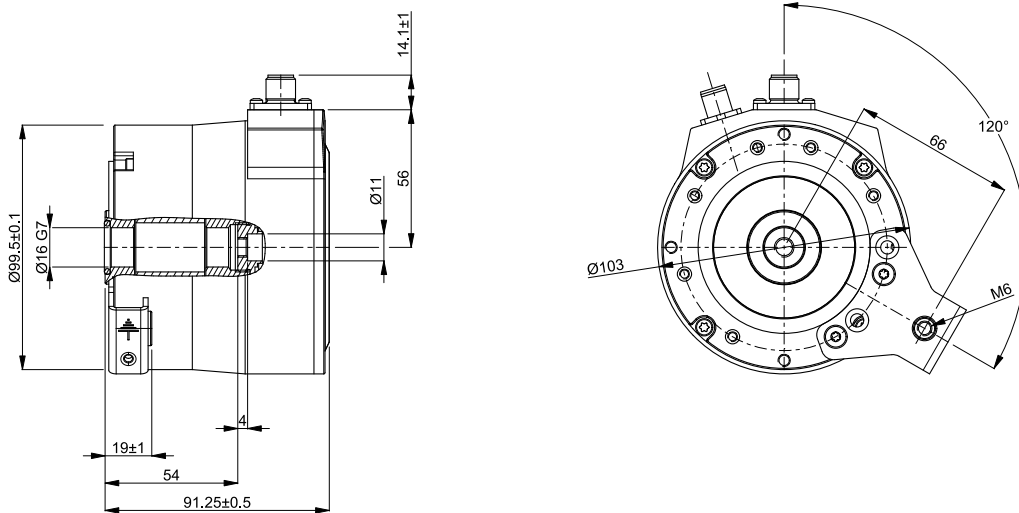

Hollow shaft with 3 x M12 connectors

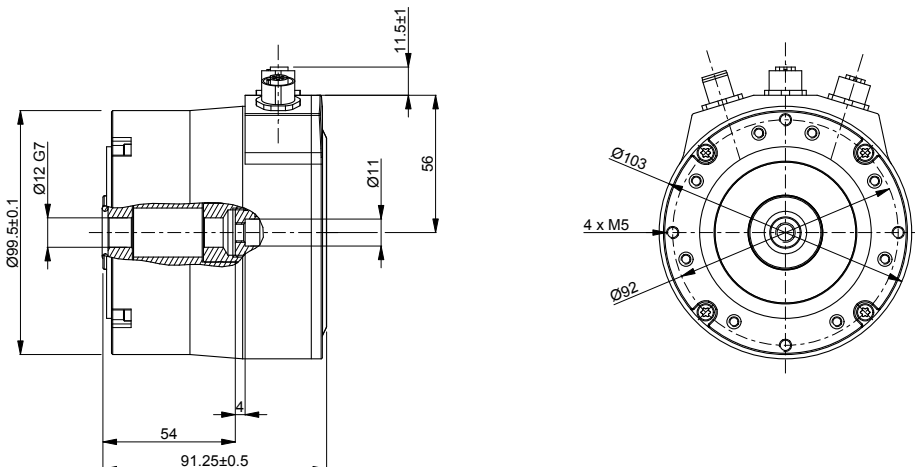

Euro-flange with 3 x M16 cable glands

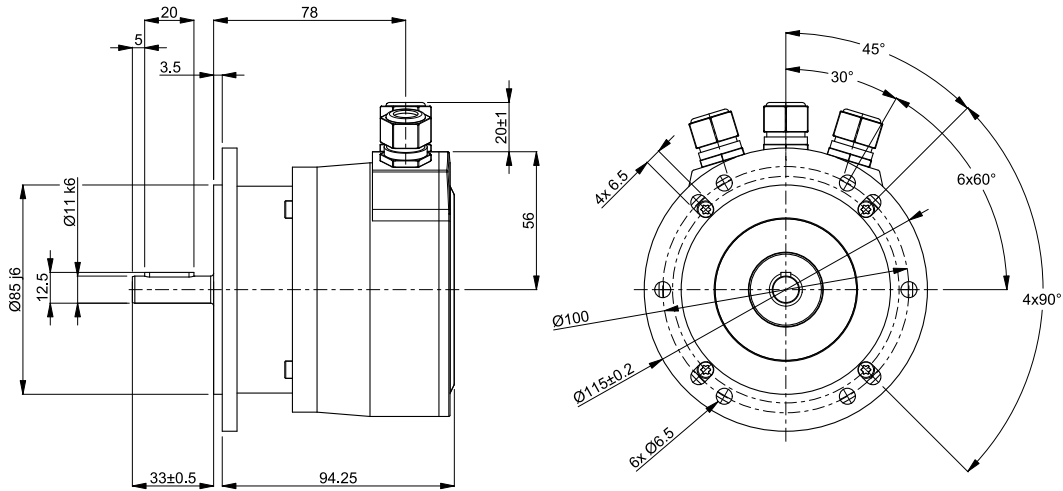

Keywayed hollow shaft with 1 x M23 connector

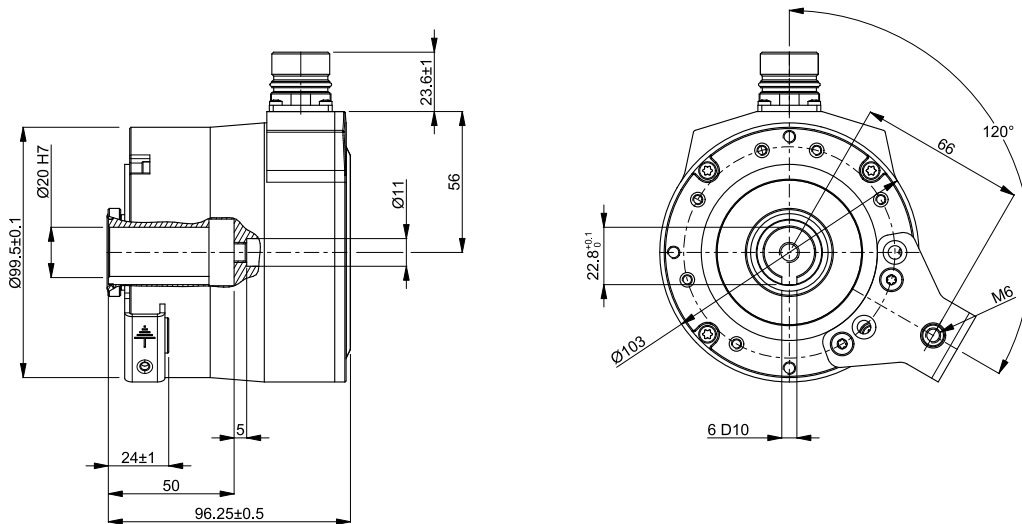

Taper hollow shaft with 1 x M20 cable gland

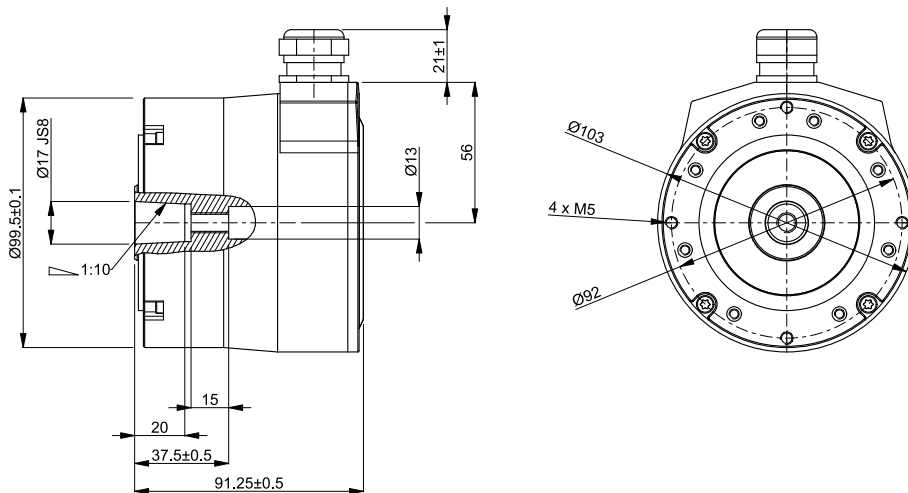

Combination encoders

Euro-flange with 3 x M12 and 1 x M23 connectors

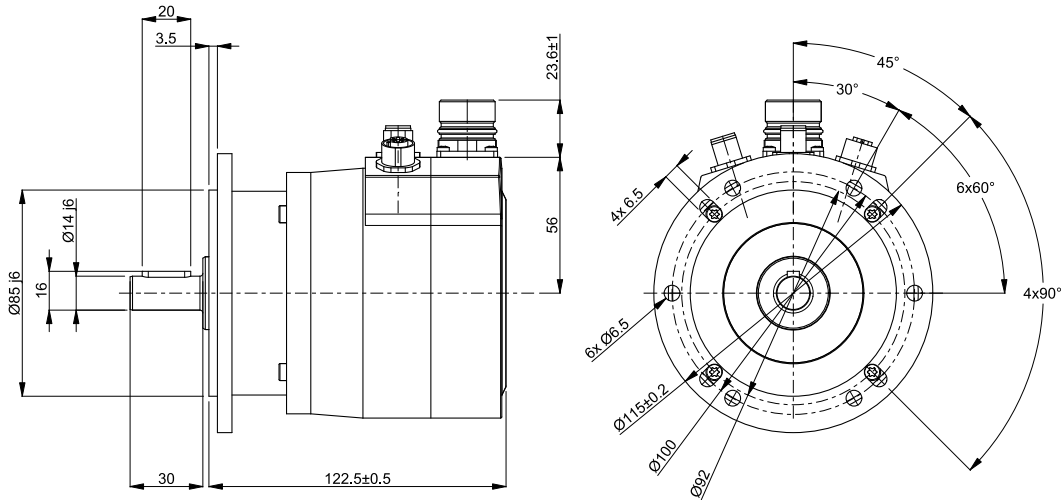

Keywayed hollow shaft with 3 x M16 and 1 x M20 cable glands

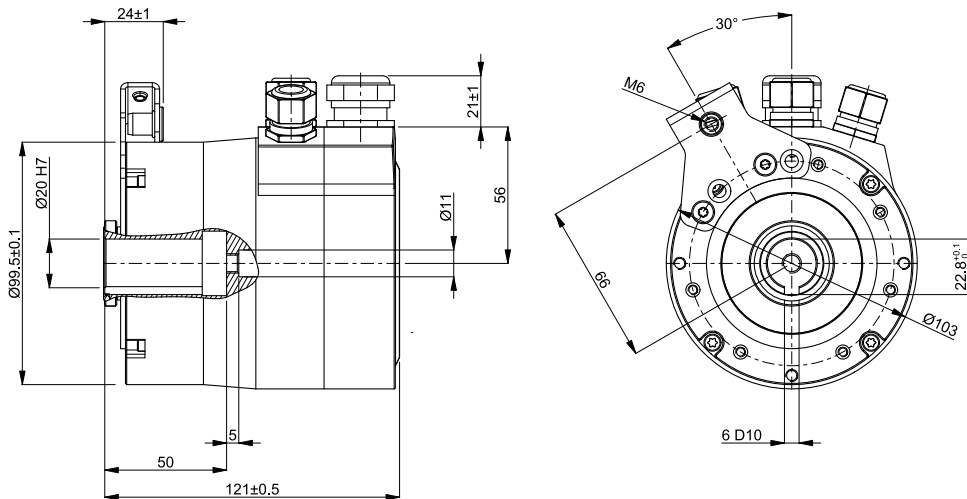

Electronics

– flexibility in interfaces

PROFIBUS

The 900 series supports the encoder profiles 3.062 (DVPO) which contains functions such as preset, scaling and code sequence.



PROFINET

PROFINET can in general be described as Ethernet-based PROFIBUS DP communication and contains functions such as preset, scaling, code sequence, slave-to-slave and isochronous data exchange.



EtherCAT

With no underlying subsystems EtherCAT has a fast Industrial Ethernet technology and is therefore suitable in applications where cycle time down to 31,25 μ s is required. The encoder interface supports CANopen over EtherCAT according to CiA 301 and the device profile CiA 406. With objects for position value, speed, and acceleration, the encoder provides a wide usability for fast EtherCAT control systems.



EtherNet/IP

EtherNet/IP is an Industrial Ethernet network that combines standard Ethernet technologies with Common Industrial Protocol, CIP. The EtherNet/IP encoders support the device profile 0x22 with available features such as preset, velocity, speed and acceleration limits, code sequence and scaling.



DRIVE-CLiQ

DRIVE-CLiQ is an Ethernet-based protocol from Siemens. With a speed of 100 Mbit/s and a cycle time of 31.25 μ s, DRIVE-CLiQ has the performance required for the most demanding applications. Components with DRIVE-CLiQ are automatically configured with each other since every component has an electronic label. The encoders are supplied with specially adapted connectors, with power supply and data in the same connector.



DRIVE-CLiQ

SSI

Synchronous Serial Interface is a digital point-to-point interface. It provides uni-directional communication at speeds up to 1.0 MHz by the use of only four wires.

SSI

EnDat 2.2

The EnDat 2.2 interface is a digital, bidirectional interface for encoders. It is capable of transmitting position values from absolute encoders, as well as reading and updating information stored in the encoder.



EnDat 2.2

Incremental

Interface	TTL	RS422	HCHTL
Supply	5 Vdc	9-30 Vdc	9-30 Vdc
Output signal	5 Vdc	5 Vdc	9-30 Vdc
Suitable for	Low frequencies over short cables	High frequencies over long cables	Medium frequencies over long cables
Max frequency	200 kHz	200 kHz	200 kHz
Max cable length	50 m at 50 kHz	1000 m (TiA/EIA-422-B)	350 m at 100 kHz



Resolution

The 900 series is available with high resolutions for absolute position data up to 19 bit singleturn and 16 bit multiturn. Depending on the communication protocol the receiving electronics may have limitations on how much data it can handle. Therefore the resolution is scaled down for certain communication protocols as described in the code keys on pages 12-13.

For incremental outputs any resolution may be selected between 1 and 32768 pulses per revolution.

Code keys

Absolute encoder models 901 and 903



Model

- 3 = Standard
- 1 = Extra robust (ceramic bearings)

Shaft

- 2 = Hollow shaft 12 mm
- 6 = Hollow shaft 16 mm
- 7 = Hollow shaft 17 mm taper (only model 901)
- 0 = Hollow shaft 20 mm with keyway (only model 901)
- 1 = Solid shaft 11 mm with key nut
- 4 = Solid shaft 14 mm with key nut

Flange

- 0 = No torque bracket (hollow shaft)
- 2 = Torque bracket 120° (hollow shaft)
- 3 = Torque bracket 330° (hollow shaft)
- 8 = Euro-flange B10 (solid shaft)

Output

Electronics	Resolution	Connection type
111 = SSI singleturn	13 bit with HTL 2048 ppr	1 x M20 cable gland
112 = SSI singleturn	13 bit with HTL 2048 ppr	Pre-mounted cable, specify length xx m
114 = SSI singleturn	13 bit with HTL 2048 ppr	1 x M23 connector 17 pin
121 = SSI multiturn	13 + 12 bit with HTL 2048 ppr	1 x M20 cable gland
122 = SSI multiturn	13 + 12 bit with HTL 2048 ppr	Pre-mounted cable, specify length xx m
124 = SSI multiturn	13 + 12 bit with HTL 2048 ppr	1 x M23 connector 17 pin
212 = EnDat 2.2 singleturn	19 bit with 1 Vpp 32 ppr	Pre-mounted cable, specify length xx m
214 = EnDat 2.2 singleturn	19 bit with 1 Vpp 32 ppr	1 x M23 connector 17 pin
222 = EnDat 2.2 multiturn	19 + 16 bit with 1 Vpp 32 ppr	Pre-mounted cable, specify length xx m
224 = EnDat 2.2 multiturn	19 + 16 bit with 1 Vpp 32 ppr	1 x M23 connector 17 pin
311 = PROFIBUS singleturn	19 bit	3 x M16 cable gland
315 = PROFIBUS singleturn	19 bit	3 x M12 connector
321 = PROFIBUS multiturn	19 + 12 bit	3 x M16 cable gland
325 = PROFIBUS multiturn	19 + 12 bit	3 x M12 connector
331 = PROFIBUS multiturn	15 + 16 bit	3 x M16 cable gland
335 = PROFIBUS multiturn	15 + 16 bit	3 x M12 connector
425 = DRIVE-CLiQ multiturn	19 + 15 bit	1 x M12 connector
426 = DRIVE-CLiQ multiturn	19 + 15 bit	1 x M12 connector + 1 x temp input for connection with external temperature sensor
515 = EtherCAT	19 bit	3 x M12 connector
525 = EtherCAT	19 + 16 bit	3 x M12 connector
615 = PROFINET	19 bit	3 x M12 connector
625 = PROFINET	19 + 16 bit	3 x M12 connector
715 = EtherNet/IP	19 bit	3 x M12 connector
725 = EtherNet/IP	19 + 16 bit	3 x M12 connector

Combination encoder models 921 and 923



Model

- 3 = Standard
- 1 = Extra robust (ceramic bearings)

Shaft

- 6 = Hollow shaft 16 mm
- 7 = Hollow shaft 17 mm taper (only model 921)
- 0 = Hollow shaft 20 mm with keyway (only model 921)
- 1 = Solid shaft 11 mm with key nut
- 4 = Solid shaft 14 mm with key nut

Flange

- 0 = No torque bracket (hollow shaft)
- 2 = Torque bracket 120° (hollow shaft)
- 3 = Torque bracket 330° (hollow shaft)
- 8 = Euro-flange B10 (solid shaft)

Absolute output

Electronics	Resolution	Connection type
111 = SSI singleturn	13 bit with HTL 2048 ppr	1 x M20 cable gland
112 = SSI singleturn	13 bit with HTL 2048 ppr	Pre-mounted cable, specify length xx m
114 = SSI singleturn	13 bit with HTL 2048 ppr	1 x M23 connector 17 pin
121 = SSI multiturn	13 + 12 bit with HTL 2048 ppr	1 x M20 cable gland
122 = SSI multiturn	13 + 12 bit with HTL 2048 ppr	Pre-mounted cable, specify length xx m
124 = SSI multiturn	13 + 12 bit with HTL 2048 ppr	1 x M23 connector 17 pin
311 = PROFIBUS singleturn	19 bit	3 x M16 cable gland
315 = PROFIBUS singleturn	19 bit	3 x M12 connector
321 = PROFIBUS multiturn	19 + 12 bit	3 x M16 cable gland
325 = PROFIBUS multiturn	19 + 12 bit	3 x M12 connector
331 = PROFIBUS multiturn	15 + 16 bit	3 x M16 cable gland
335 = PROFIBUS multiturn	15 + 16 bit	3 x M12 connector
615 = PROFINET	19 bit	3 x M12 connector
625 = PROFINET	19 + 16 bit	3 x M12 connector
715 = EtherNet/IP	19 bit	3 x M12 connector
725 = EtherNet/IP	19 + 16 bit	3 x M12 connector

Incremental output

Electronics (supply / output)	Connection type
91 = HCHTL (9-30 V / 9-30 V)	1 x M23 connector 12 pin
92 = HCHTL (9-30 V / 9-30 V)	1 x M20 cable gland
93 = RS422 (9-30 V / 5 V)	1 x M23 connector 12 pin
94 = RS422 (9-30 V / 5 V)	1 x M20 cable gland
95 = TTL (5 V / 5 V)	1 x M23 connector 12 pin
96 = TTL (5 V / 5 V)	1 x M20 cable gland

Incremental resolution

1-32768 ppr

Other options may be available upon request.

Performance

Technical data (PHE 903 PROFIBUS)

Ingress protection class [IEC 60529]	IP67 (IP66 at shaft inlet)
Shock [IEC 60068-2-27]	1500 m/s ²
Vibration [IEC 60068-2-6]	200 m/s ²
Operating temperature	-20 °C .. +70 °C * (up to +100 °C with SSI or EnDat)
Shaft load axial / radial	125 N / 400 N
Weight	1600 g
Cover material	Aluminum (anodized)
Shaft material	Stainless steel with insulation
Rotational speed max	6000 rpm

* -40 °C with ceramic bearings

Contact us

SWEDEN / HEAD OFFICE

T +46-(0)152-265 00
F +46-(0)152-265 05
info@leinelinde.com

BRAZIL

T +55-19-3291-8425
F +55-19-3367-5658
info@leinelinde.com.br

FINLAND

T +358-(0)9-561 72 00
F +358-(0)9-561 72 020
info@leinelinde.fi

ITALY

T +39-039-596 01 08
F +39-039-971 22 08
info@leinelinde.it

CHINA

T +86-(021)-52 58 35 66
F +86-(021)-52 58 35 99
info@leinelinde.cn

GERMANY

T +49-(0)40-3176758-60
F +49-(0)40-3176758-65
info@leinelinde.de

SOUTH KOREA

T +82-(0)51-746 5420
F +82-(0)51-746 5421
info@leinelinde.co.kr

DENMARK

T +45-862-308 34
info@leinelinde.dk

INDIA

T +91-11-2617 2504
F +91-11-2616 5449
info@leinelinde.in

SPAIN

T +34-93-574 23 02
F +34-93-560 57 60
info@leinelinde.es

Leine Linde's worldwide presence. Read more at www.leinelinde.com

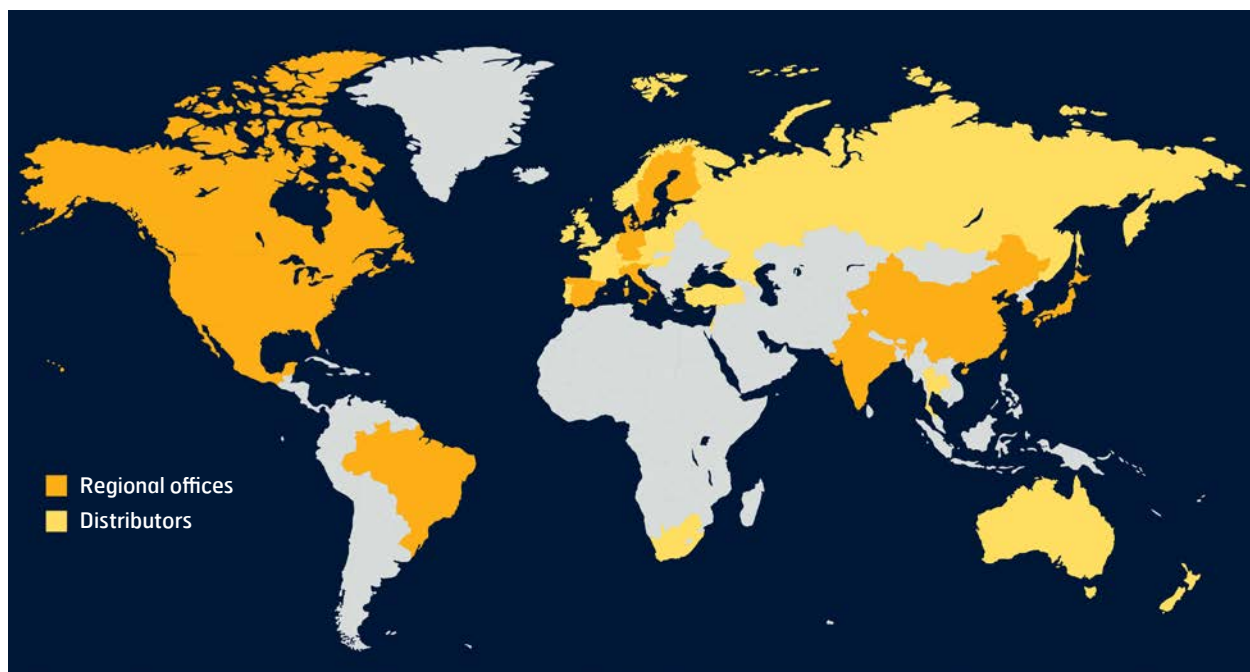

The best encoders are those you never have to think about. Those that simply do their job – year after year. Leine Linde develops and manufactures customised encoder solutions for demanding environments, advanced measuring systems for accurate feedback of speed and position.

LEINE  LINDE

+46-(0)152-265 00 www.leinelinde.com