



MC800

Universal Motion Controller

Product features:

- Suitable for various applications of drive technology, e.g.: Synchronization Control, Index and Print Mark Evaluation Control, Rotating Cross Cutter Control, Flying Saw Control, Eccentric Shear Control, Label Printing Machine Control, etc.
- Interface module (option), e. g. CANopen, Modbus, Profibus DPV1
- Free assignment of the control axes and index or print mark inputs
- New included control loop enables to run torque loop applications
- Tandem Drive Control

Version:	Description:
MC80001a_oi_e/ag	First edition
MC80001b_oi_e/ag	Some pin-assignment corrections
MC80001c_oi_e/ag	Power consumption changed from 150 to 250 mA
MC80001d_oi_e/ag	Output current of the encoder supplies modulated to 150 mA (each)
Mc800_01e_oi_e/ag	Correction of the serial interface in chapter "Technical Specifications"
Mc800_02a_oi_d/TJ	Interface modules updated
Mc800_02b_oi_d/TJ	Serial interface updated
Mc800_02c_oi_d/TJ	DIL switch settings updated

Legal notices:
<p>All contents included in this manual are protected by the terms of use and copyrights of motrona GmbH. Any reproduction, modification, usage or publication in other electronic and printed media as well as in the internet requires prior written authorization by motrona GmbH.</p>

Table of Contents

1. Safety Instructions and Responsibility	4
1.1. General Safety Instructions	4
1.2. Use according to the intended purpose.....	4
1.3. Installation	5
1.4. Cleaning, Maintenance and Service Notes.....	5
2. General	6
2.1. About MC800.....	6
2.2. Operational Area.....	6
2.3. Essential Advantages	6
3. Power Supply	6
4. Encoder inputs	7
4.1. HTL / TTL and RS-422 Inputs	7
4.2. SSI Inputs.....	7
4.3. SinCos Inputs	8
5. Digital & Analog Inputs	8
5.1. Control and Fast Interrupt Inputs.....	8
5.2. Analog Inputs.....	9
6. Digital & Analog Outputs	9
6.1. Control Outputs.....	9
6.2. Incremental Output.....	10
6.3. Analog Outputs	10
7. DIL-Switch	11
8. Status LEDs	11
9. Interfaces and Bus Connections	12
9.1. Operator Software	12
9.2. Serial Interfaces (On-Board)	12
9.3. USB 2.0 Interface.....	14
9.4. Ethernet	14
9.5. Optional Interface Modules.....	14
10. Mechanical Installation	14
11. Dimensions	15
11.1. Housing (without connectors).....	15
11.2. Housing (inclusive connectors).....	16
12. Technical Specifications	17

1. Safety Instructions and Responsibility

1.1. General Safety Instructions

This operation manual is a significant component of the unit and includes important rules and hints about the installation, function and usage. Non-observance can result in damage and/or impairment of the functions to the unit or the machine or even in injury to persons using the equipment!

Please read the following instructions carefully before operating the device and observe all safety and warning instructions! Keep the manual for later use.

A pertinent qualification of the respective staff is a fundamental requirement in order to use these manual. The unit must be installed, connected and put into operation by a qualified electrician.

Liability exclusion: The manufacturer is not liable for personal injury and/or damage to property and for consequential damage, due to incorrect handling, installation and operation. Further claims due to errors in the operation manual as well as misinterpretations are excluded from liability.

In addition the manufacturer reserves the right to modify the hardware, software or operation manual at any time and without prior notice. Therefore, there might be minor differences between the unit and the descriptions in operation manual.

The raiser respectively positioner is exclusively responsible for the safety of the system and equipment where the unit will be integrated.

During installation or maintenance all general and also all country- and application-specific safety rules and standards must be observed.

If the device is used in processes, where a failure or faulty operation could damage the system or injure persons, appropriate precautions to avoid such consequences must be taken.

1.2. Use according to the intended purpose

The unit is intended exclusively for use in industrial machines, constructions and systems. Non-conforming usage does not correspond to the provisions and lies within the sole responsibility of the user. The manufacturer is not liable for damages which have arisen through unsuitable and improper use. Please note that device may only be installed in proper form and used in a technically perfect condition - in accordance to the "Technical Specifications".

The device is not suitable for operation in explosion-proof areas or areas which are excluded by the EN 61010-1 standard.

1.3. Installation

The device is only allowed to be installed and operated within the permissible temperature range. Please ensure adequate ventilation and avoid all direct contact between the device and hot or aggressive gases and liquids.

Before installation or maintenance, the unit must be disconnected from all voltage-sources. Further it must be ensured that no danger can arise by touching the disconnected voltage-sources.

Devices which are supplied by AC-voltages must be connected exclusively by switches, respectively circuit-breakers with the low voltage network. The switch or circuit-breaker must be placed as near as possible to the device and further indicated as separator.

Incoming as well as outgoing wires and wires for extra low voltages (ELV) must be separated from dangerous electrical cables (SELV circuits) by using double or increased isolation.

All selected wires and isolations must be conforming to the provided voltage- and temperature-ranges. Further all country- and application-specific standards, which are relevant for structure, form and quality of the wires, must be ensured. Instructions about the permissible wire cross-sections for wiring are described in the chapter "Technical Specifications".

Before first start-up it must be ensured that all connections and wires are firmly seated and secured in the screw terminals. All (inclusively unused) terminals must be fastened by turning the relevant screws clockwise up to the stop.

Overvoltage at the connections must be limited to values in accordance to the overvoltage category II.

For placement, wiring, environmental conditions, as well as shielding and earthing/grounding of the supply lines, the general standards of industrial automation industry and the specific shielding instructions of the manufacturer are valid. Please find all respective hints and rules on www.motrona.com/download.html --> "[General EMC Rules for Wiring, Screening and Earthing]".

1.4. Cleaning, Maintenance and Service Notes

To clean the front of the unit please use only a slightly damp (not wet!), soft cloth. For the rear no cleaning is necessary. For an unscheduled, individual cleaning of the rear the maintenance staff or assembler is self-responsible.

During normal operation no maintenance is necessary. In case of unexpected problems, failures or malfunctions the device must be shipped back to the manufacturer for checking, adjustment and reparation (if necessary). Unauthorized opening and repairing can have negative effects or failures to the protection-measures of the unit.

2. General

2.1. About MC800

The MC800 device is a universally applicable controller, which serves for sophisticated motion control tasks in today's machine engineering and drive technology. Functions, features and settings are dependent on the equipped controller firmware. This operation manual is limited especially to the hardware features of the MC800 and includes all hardware relevant data, e. g. wiring rules and technical specifications. Pure functional features and instructions for the setting-up operation are available in the relevant application file within the CD-ROM library.

2.2. Operational Area

The application range of the MC800 is very diverse. Typical control applications are e. g. drive synchronization, index and print mark evaluation, rotating cross cutters, flying, eccentric shears, label printing machines, etc..

2.3. Essential Advantages

The follow-up unit to the proof MC700 convinces by its higher band width and more flexible bus architecture. A really special feature of the MC800 is the integrated tandem drive controller. This allows reaching acceleration requirements of heavy loads by splitting the necessary power into two independent drives.

3. Power Supply

The unit is supplied with an unstabilized DC voltage of 18... 35 VDC. The supply voltage must be connected by the pluggable screw terminal X3. The power consumption depends on the power supply level as well as the load of the + 5 V encoder supply. In unloaded condition the consumption is about 250 mA.

Connections:

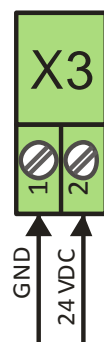

4. Encoder inputs

The universal MC800 controller is equipped with numerous inputs for diverse encoder types. This chapter describes the pin assignment of each connector.

4.1. HTL / TTL and RS-422 Inputs

The pluggable 9-pin screw terminals X7 and X9 are used for the incremental encoder connections. The encoder can be supplied by two different voltages, 5.2 VDC (max. 150 mA per terminal) or 16 to 33 VDC (max. 150 mA per terminal). Both inputs allow to connect HTL, TTL and RS422 (A, /A, B, /B, Z, /Z) encoders. If no index evaluation is needed, the Z-pulse channels can be left unconnected.

Connections:

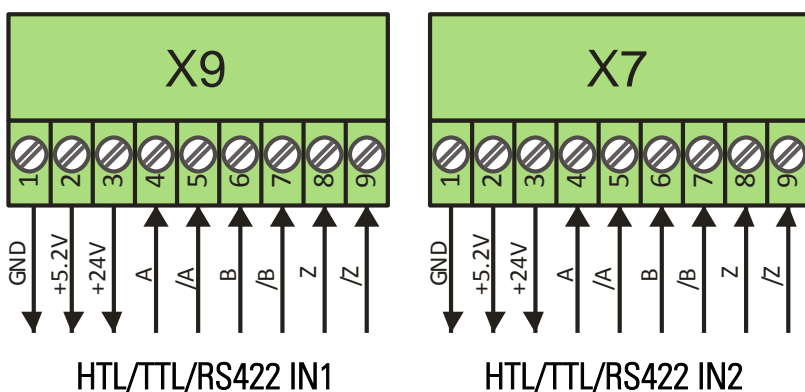

4.2. SSI Inputs

Supplemental to the incremental inputs two further inputs for connecting absolute SSI encoders are available at the terminals X8 and X10. These selectively can be operated as Master or Slave from 100 Hz up to 1 MHz. The resolution is 13 ... 32 bit. Optionally these inputs can be used as additional RS422 incremental inputs with channels A, /A, B, /B.

Connections:

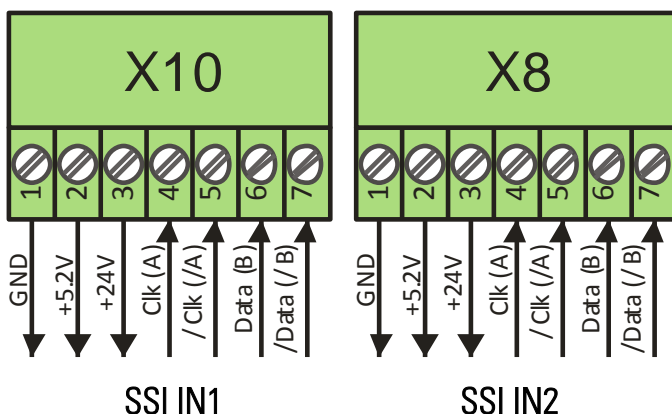

4.3. SinCos Inputs

Two further inputs for 1 Vpp SinCos rotary encoders (SIN+, SIN-, COS+, COS-, REF+ and REF-) are available at the 9-pin (male) SUB-D connectors X1 and X2. These can be combined with any other encoder inputs of the MC800. Frequencies up to 400 kHz can be processed here.

Connections:

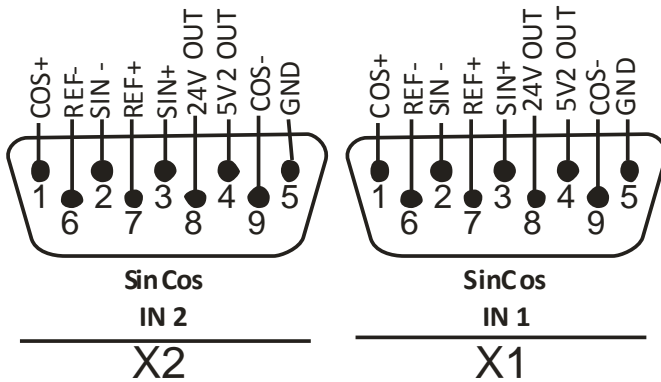

5. Digital & Analog Inputs

5.1. Control and Fast Interrupt Inputs

4 fast interrupt inputs (e. g. for light sensitive barriers or photocells) and 4 static inputs for control tasks are available at the pluggable screw terminal X4. The fast interrupt inputs are NPN / PNP – HTL and the 4 control inputs PNP – HTL, LOW < 2.5 VDC / HIGH > 10 VDC (24 VDC).

Connections:

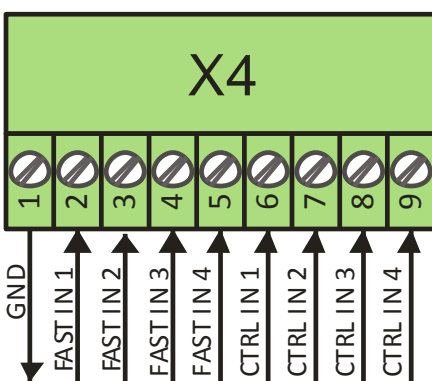

5.2. Analog Inputs

Two analogue inputs at the 6-pin terminal X12 allow connecting external set points or linear potentiometers. Both inputs are connectable with 0...+/-10 V or 0 (4)... 20 mA (burden 100 Ohm). The resolution is 14 Bit (± 13 Bit) with an accuracy of 0.1 %. The reference voltage for linear potentiometers is 4.096 V.

Connections:

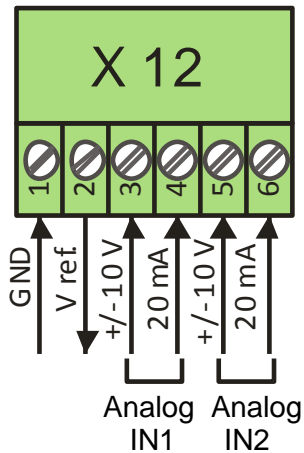

6. Digital & Analog Outputs

6.1. Control Outputs

At the 6-pin screw terminal X5 four digital push-pull outputs (marked with Out1, 2, 3, 4) are available. The range of possible switching voltages is 5 ... 30 VDC (depending on the voltage level at „Com+“). All control outputs are protected by a short proof circuit. The delay time is < 1 ms.

Connections:

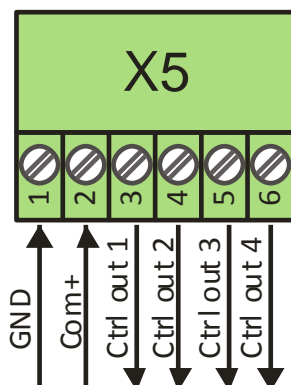

6.2. Incremental Output

The screw terminal X6 delivers an incremental output with three differential channels (A, /A, B, /B, Z, /Z) and an output frequency of maximum 500 KHz. The differential voltage amounts from 3.5 up to 30 VDC (depends on voltage at the "Com+" input).

Connections:

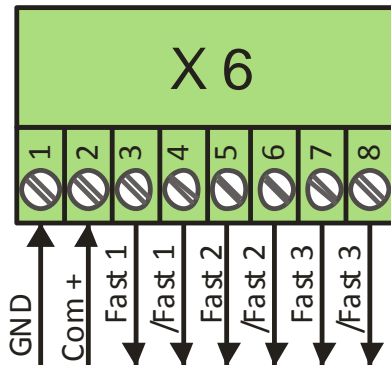

Depending on the firmware, this output can be used for the following purposes:

- Output of a frequency or pulse number as speed- or position-set-point for a servo drive with an incremental input (*in preparation, not yet available*)
- Output of a pilot frequency for virtual master drive applications (*in preparation, not yet available*)
- Cascading of several controllers (output of the signals of one of the encoder inputs)
- Additional digital control outputs

6.3. Analog Outputs

At the screw terminal X13 two short circuit proof analog outputs are available. Both outputs provide 0... ±10 V (maximum load 2 mA) as well as 0/4... 20 mA (max. burden 270 Ohm). These outputs can be used as drive set-points or for arbitrary other regulating functions.

Connections:

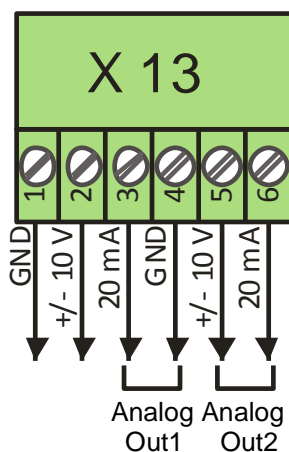

7. DIL-Switch

The DIL-switch provides the following settings:

DIL-Switch 1: Selects the protocol for the serial interface:

OFF: Serial interface is using Lecom protocol (motrona standard)

ON: Serial interface is using Modbus RTU protocol

DIL-Switch 2: Not used (reserved for further functions)

DIL-Switch 3: For factory testing only, please do not use. **Must be set to OFF.**

8. Status LEDs

On the left side of the DIL-switch 3 LEDs for diverse status messages are located.

- Green LED → ready for operation „ON“
- Yellow LED → status message 1
- Yellow LED → status message 2

9. Interfaces and Bus Connections

For communication with external operator terminals, devices, computers or superior control systems the unit is equipped with diverse interfaces, which are described below.

9.1. Operator Software

The controller can be adjusted and operated by using the motrona software OS 5.1

9.2. Serial Interfaces (On-Board)

Each interface (RS232 and RS485) can be connected with the 9-pin (female) SUB-D connector X11.

Important note: It is impossible to communicate with the MC800 via both interfaces at the same time!

The serial interface operates asynchronously either with Lecom protocol or Modbus RTU and with selectable Baud rates from 9600 up to 38400 bps.

The serial protocol is selected by DIL switch 1 (see chapter 7).

Connections:

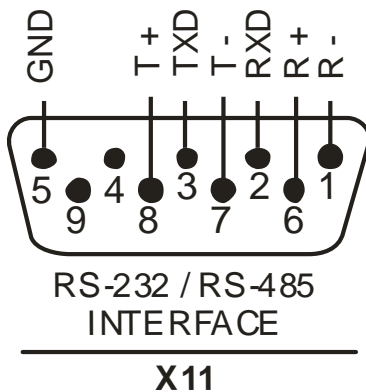

9.2.1. RS232

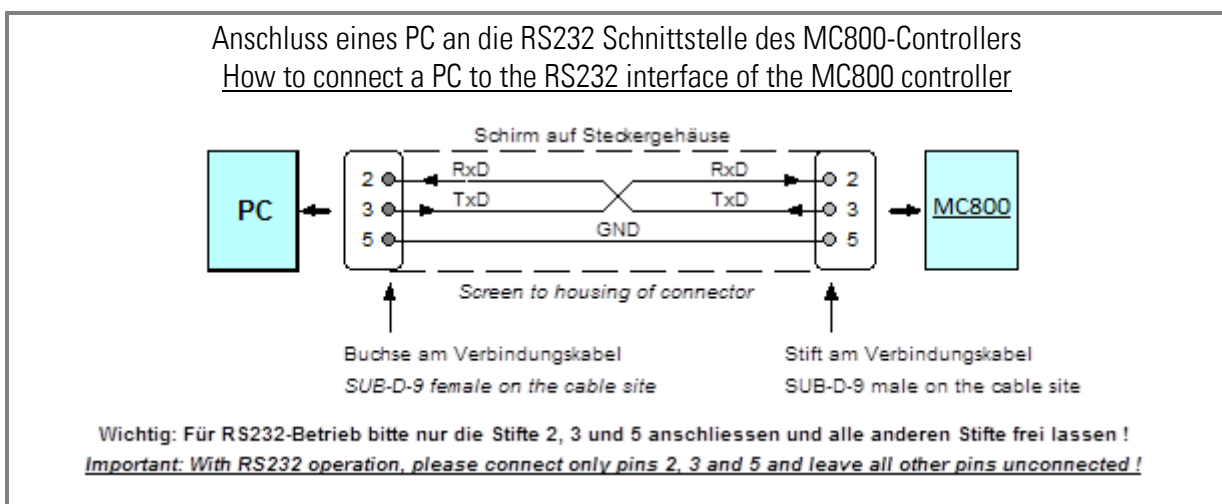

9.2.2. RS485

The RS485 interface provides both, 2-wire mode and 4-wire mode.

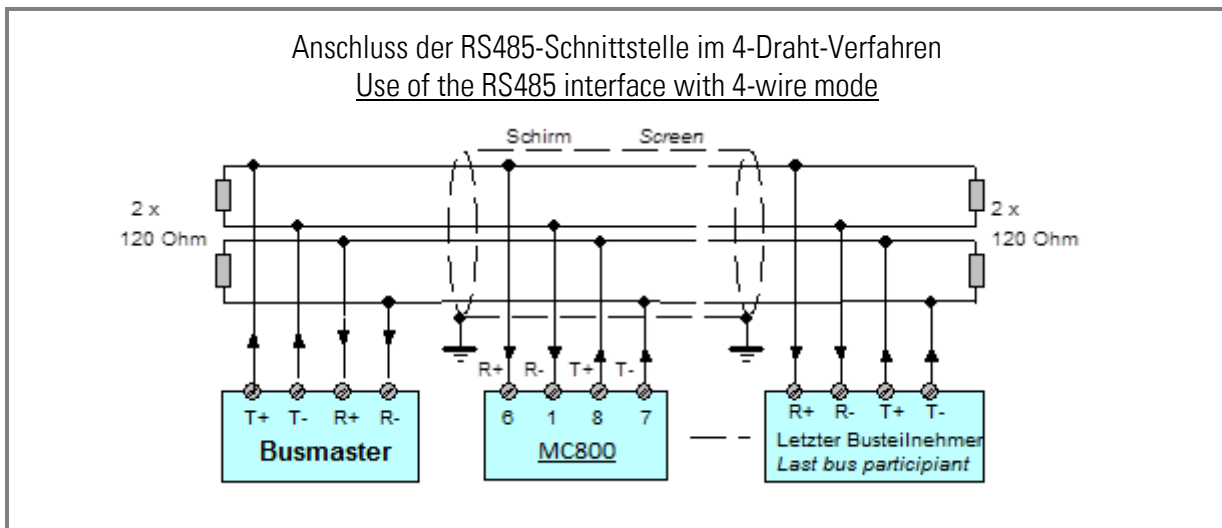
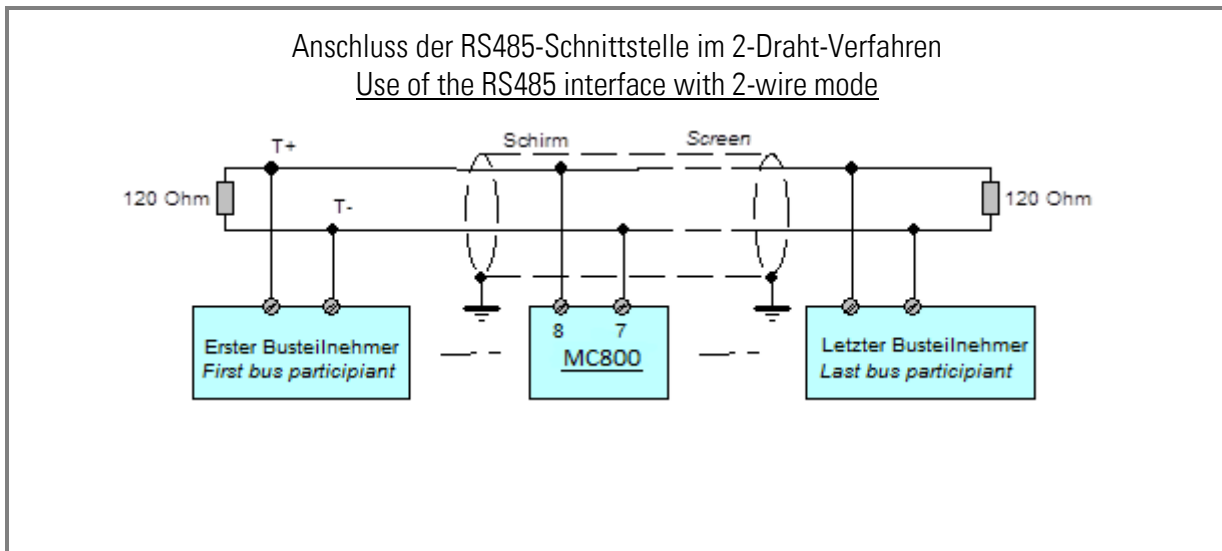

9.3. USB 2.0 Interface

- Connection by a female USB Type B port.
- Serves for firmware download
- Interface operates as USB-Device
- Device Class: CDC (Communication Device Class)

9.4. Ethernet

The MC800 is already equipped with an on-board Ethernet TCP / IP interface, which is used only for parameter settings. The Ethernet connection of the MC800 is based on the IEEE.802.3 standard with a transfer rate of 10 Mbps.

Function in preparation, not yet available

9.5. Optional Interface Modules

Optional plug-in modules for fieldbus or ethernet communication.

The following interfaces are currently available:

- CANopen
- Profibus DPV1
- Modbus RTU

In preparation / available on request:

- CC-Link
- DeviceNet
- EtherCAT
- Ethernet / IP
- Modbus TCP
- Powerlink
- Profinet
- SERCOS-III

10. Mechanical Installation

The MC800 easily can be fastened by snapping onto a mounting rail (35 mm C-Profile).

11. Dimensions

11.1. Housing (without connectors)

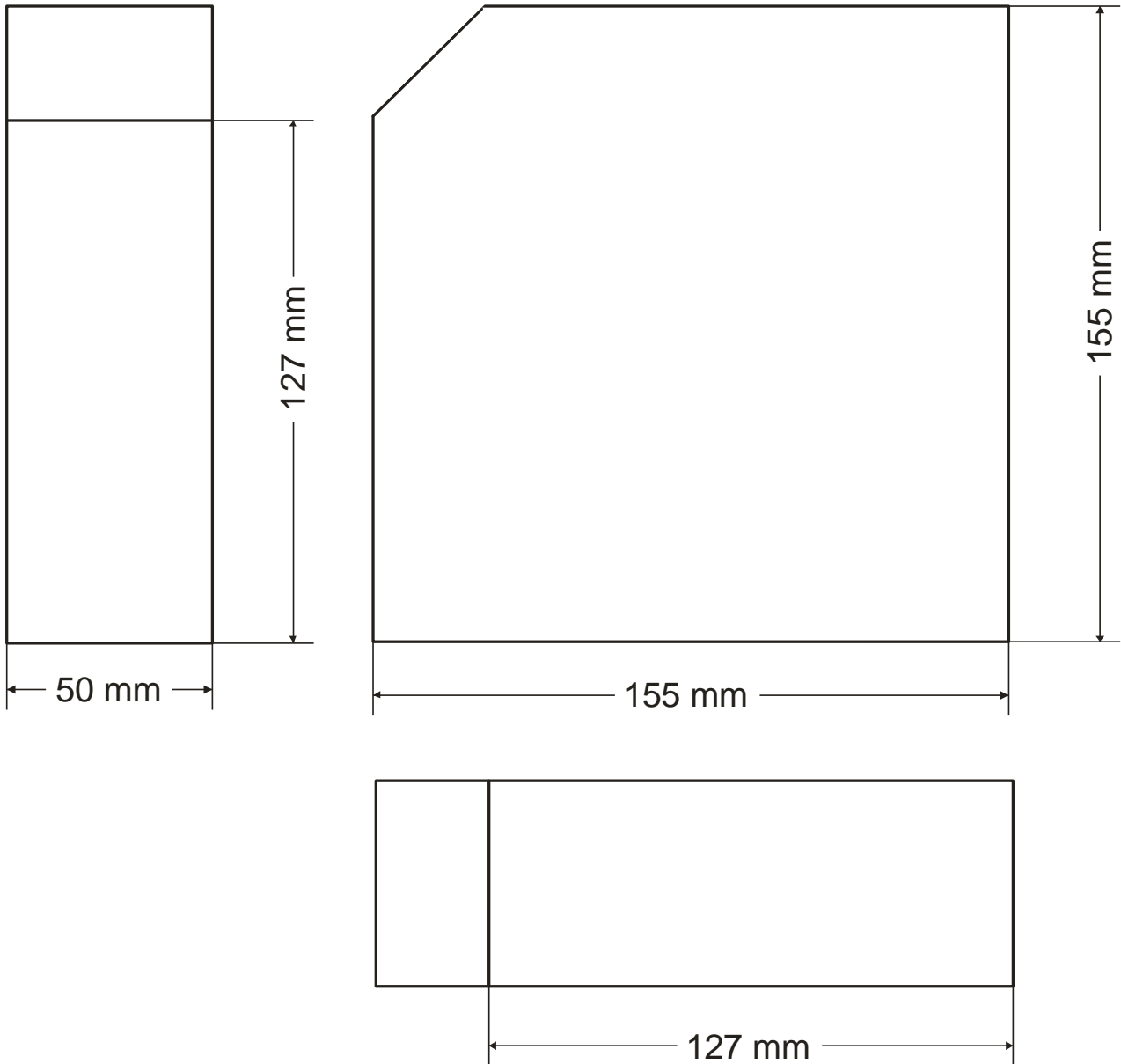

11.2. Housing (inclusive connectors)

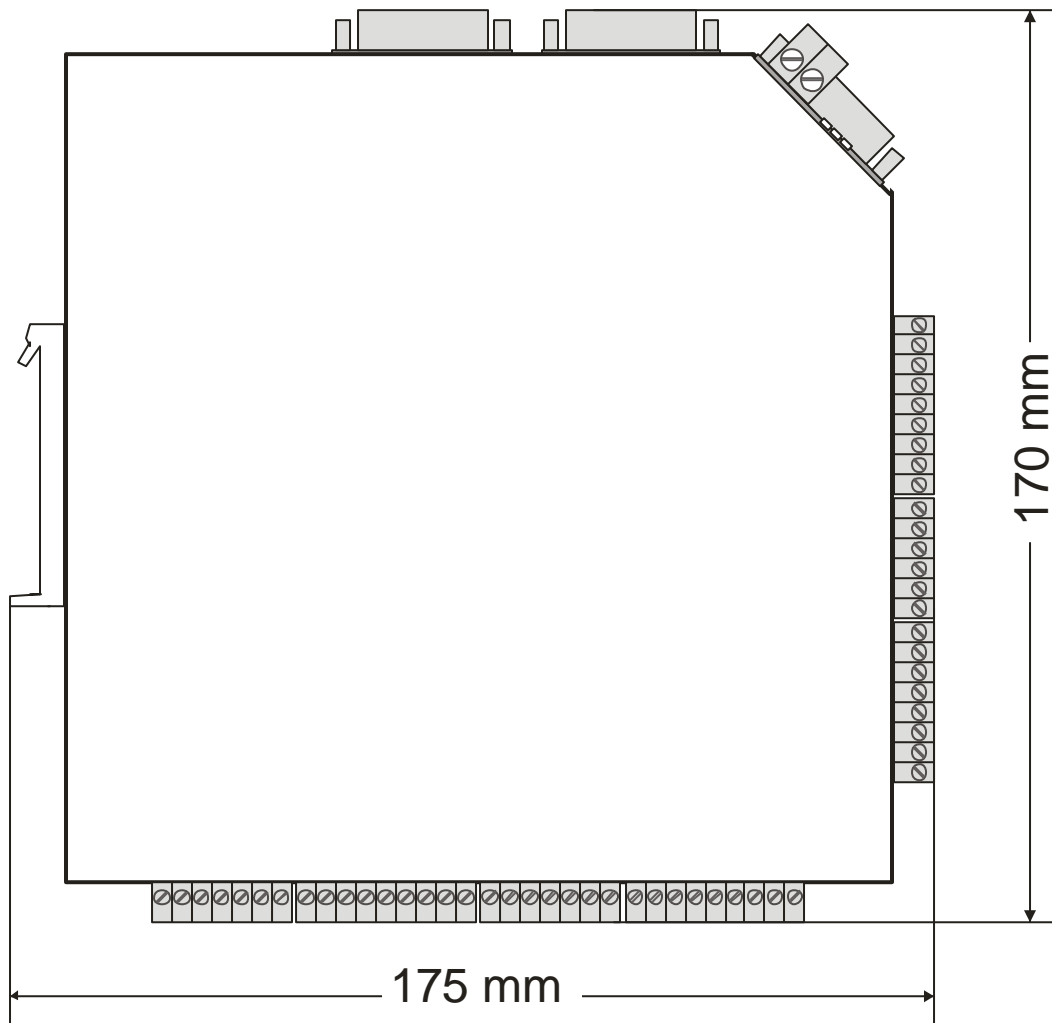

12. Technical Specifications

Power supply:	Input voltage: Protection circuit: Consumption: Connections:	18 ... 35 VDC reverse polarity protection approx. 250 mA (unloaded) screw terminal, X3, 2-pin, 1.5 mm ² / AWG 16
Encoder supply:	Output voltages: Output current: Protection circuit:	2 x 5.2 VDC and 2 x 16 ... 33 VDC (input voltage minus ca. 2 V) 5.2 VDC max. 150 mA (per terminal) 16... 33 VDC max. 150 mA (per terminal) reverse polarity protection
SinCos inputs:	Number of inputs: Amplitude: DC offset: Frequency: Connections:	2 min. 0.8 ... max. 1.2 Vpp min. 1.8 ... max. 3.1 V max. 400 kHz SUB-D (male) connectors, X1 and X2, 9-pin
Incremental inputs:	Number of inputs: Format: Frequency: Differential voltage: Connections:	2 RS422 (differential signal A, /A, B, /B, Z, /Z) max. 2 MHz > 1 VDC screw terminals, X9 and X7, 9-pin, 1.5 mm ² / AWG 16
Control inputs:	Number of inputs: Application: Signal level: Pulse width: Input resistance: Connections:	4 fast interrupt-inputs (light barriers, photocells, ...) NPN/PNP HTL, LOW < 2.5 VDC - HIGH > 10 VDC min. 4 µs Ri ≈ 3 kOhm screw terminal, X4, 9-pin, 1.5 mm ² / AWG 16
	Number of inputs: Application: Signal level: Pulse width: Input resistance: Connection:	4 control inputs PNP HTL, LOW < 2.5 VDC - HIGH > 10 VDC min. 1 ms Ri ≈ 10 kOhm screw terminal, X4, 9-pin, 1.5 mm ² / AWG 16
SSI inputs: (On request)	Number of inputs: SSI-Mode: Frequency: Resolution: Format: Connection:	2 Master and Slave 100 Hz ... 1 MHz 13 ... 32 Bit RS422, optionally as pulse input 2 x A, /A, B, /B screw terminals, X10 and X8, 7-pin, 1.5 mm ² / AWG 14
Analogue inputs:	Number of inputs: Current input: Voltage input: Reference voltage: Resolution: Accuracy: Delay period: Connection:	2 0/4 ... 20 mA 0 ... ±10 V (Ri ≈ 100 kOhm) 4.096 VDC (to connect linear potentiometers) 14 Bit (±13 Bit) 0.1 % < 1 ms screw terminal, X12, 6-pin, 1.5 mm ² / AWG 16
Incremental outputs:	Number of outputs: Format: Frequency: Differential voltage: Output current: Connection:	1 Differential signal A, /A, B, /B, Z, /Z max. 500 kHz 3.5 ... 30 VDC (depends „Com+“ input level) 30 mA each channel screw terminal, X6, 8-pin, 1.5 mm ² / AWG 16

Control outputs:	Number of outputs: 4 Output voltage: 5 ... 30 VDC (depends on "Com+" input level) Output current: max. total 350 mA Output Driver: push-pull Protective circuit: short-circuit-proof Delay period: < 1 ms Connection: screw terminal, X5, 6-pin, 1.5 mm ² / AWG 16
Analogue outputs:	Number of outputs: 2 Output voltage: 0 ... ±10 V (load max. 2 mA) Output current: 0/4 ... 20 mA (load max. 270 Ohm) Resolution: 14 Bit (±13 Bit) Accuracy: 0.1% Delay period: < 1 ms Protective circuit: short-circuit-proof Connection: screw terminal, X13, 6-pin, 1.5 mm ² / AWG 16
Serial interface:	Format: RS232 or RS485 (only one can be used at the same time) asynchronous Data transmission: 2400 ... 38400 Baud rate: Lecom protocol (extended addressing) Protocol: SUB-D female, X11, 9-pin Connection:
USB-interface:	Version: USB 2.0 Connection: USB-B
Ethernet TCP / IP:	Standard: IEEE 802.3 Transmission rate: 10 ... 100 Mbps Parameterization: Full / Half Duplex Connection: RJ45
Interface module: (optional)	Ethernet Interface: (In preparation / on request: EtherCAT, Ethernet/IP, Modbus TCP, Powerlink, PROFINET, SERCOS-III)
	Fieldbus Interface (Slave): CANopen, Modbus RTU, Profibus DPV1 (In preparation / on request: CC-Link, DeviceNet)
Display:	Number of LEDs: 3 Green LED: Ready for operation „ON“ Yellow LED: Status 1 Yellow LED: Status 2
Switches:	DIL-switch: 3-pin
Conformity & standards:	EMC 2004/108/EG: EN 61000-6-2 Guideline 2011/65/EU: EN 61000-6-3 RoHS conform
Housing:	Material: plastic Mounting: mm top hat rail (according to EN 60715) Dimensions (w x h x d): 50 x 160 x 160 mm / 1.969 x 6.299 x 6.299 inch Weight: ca. 450 g Protection class: IP20
Ambient temperature:	Operating: 0 °C ... +60 °C / 32 °F ... 140 °F (not condensing) Storage: -25 °C ... +70 °C / -11.2 °F ... 158 °F (not condensing)