

X-heavy duty Hollow shaft encoder, Incremental

- Performance hollow shaft encoder for heavy duty industries
- Hybrid bearings for extended lifetime
- High vibration and shock resistance
- Electrically insulated shaft; up to 2,5 kV



Mechanical data

Operating temperature	-40 °C...+85 °C
Ingress protection class [IEC 60529]	IP67 (IP66 at shaft inlet)
Vibration [IEC 60068-2-64]	≤ 20 g, 55-2000 Hz
Shock [IEC 60068-2-27]	≤ 400 g, 3.5 ms
Shaft load (axial/radial)	500 N / 1200 N
Rotational speed max	6000 rpm
Shaft material	Stainless steel with insulated hybrid bearings
Cover material	Aluminium (coated)
Weight	1300 g

Encoder config

Code key description	862209126
Type	XHI
Model	862 Extra Robust
Shaft type	Ø17 mm taper hollow shaft
Flange type	86-flange
Resolution	2048 ppr
Power supply	9-30 Vdc
Output signal	HCHTL
Connection type	M23 connector 12-pin
Pin layout	CW
Number of channels	6 (S00, S00\, S90, S90\, Sref, Sref\)
Overvoltage protection	With overvoltage protection
Torque bracket	330° orientation

Electrical data

Polarity protected	Yes
Short circuit protected outputs	Yes
Current consumption	60 mA at 24 Vdc (Max. 80 mA)
Incremental output load (max)	± 40 mA
Output frequency max	200 kHz
Cable length max	350 m at 100 kHz
Channel separation	90 °el ± 25 °el
Dividing error	± 50 °el

Dimensions

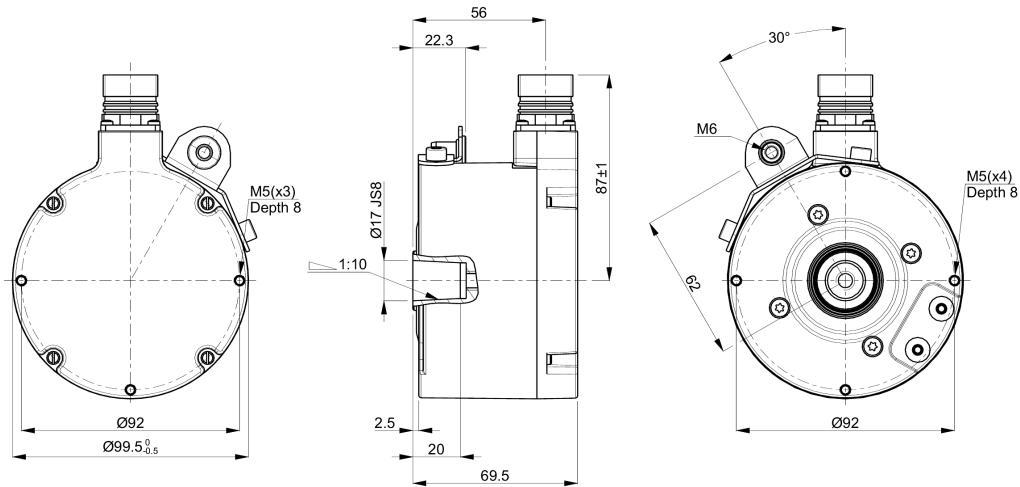

Output signal

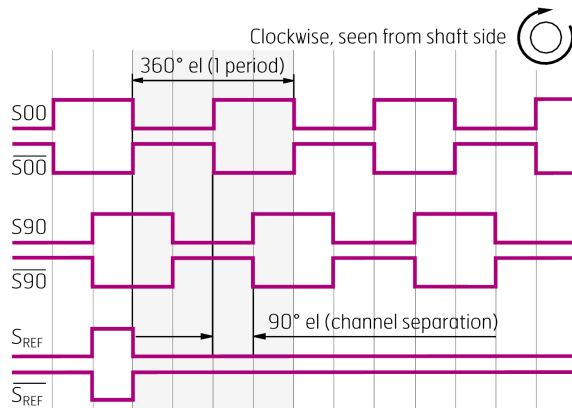

Pin Configuration

Function	Pin
+E Volt	12
0 Volt	10
0 (Sref)	3
0 inverted (Sref\)	4
1 (S90)	8
1 inverted (S90\)	1
2 (S00)	5
2 inverted (S00\)	6

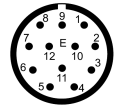

Available options

Advanced Diagnostic System

Order information

Part number 768575-01