

## Incremental double Heavy Duty hollow shaft encoder

- ▶ Extremely robust housing for harsh environments
- ▶ Shock and vibration protected
- ▶ IP 65, encapsulation class
- ▶ Two galvanically separated encoders in one housing
- ▶ Short-circuit protected outputs



865

### ELECTRICAL SPECIFICATION

Supply voltage +EV	9-30V	5V ±10%
	Polarity protected	—
Current consumption at no load	65mA @ 24V Max 80mA	85mA Max 155mA
Line counts	150...5000	
Acrylic glass	2x 500, 1000, 1024, 2048, 3072, 3600	
Glass	2x 4096, 5000, 6350, 10 000	
	Other pulserates, contact Leine & Linde	
Measuring steps	4 x line counts	
Accuracy	1-5000ppr	5001-10000ppr
Dividing error	± 50° el	± 90° el
Channel separation	90° ± 25° el	90° ± 45° el
Outputs	HTL	RS-422
	Short circuit protected	
Load max	± 40mA	± 20mA
Max cable length	200m @ 50kHz	1km (TIA/EIA-422-B)
U <sub>high</sub> (at 10mA load)	> +EV - 4,0V	> 3,0V
U <sub>low</sub> (at 10mA load)	< 2,5V	< 1,15V
Frequency range	0...100kHz	0...200kHz

### ACCESSORIES

Torque arm	
M5	Part. No. 01208013
M6	Part. No. 01208014

### OUTPUT CIRCUIT

Output A: High current HTL

Output A, B: Linedriver

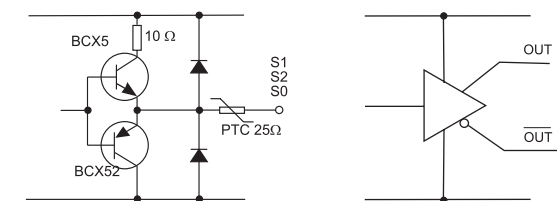

### OUTPUT SIGNALS

High current HTL:

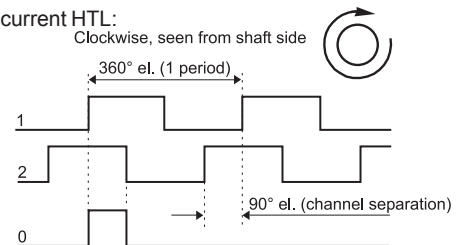

Line Driver:

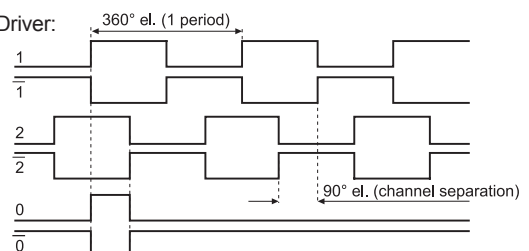

### CONNECTION

Function	Colour	Terminal
1	Green	See drawing or label
1	White	
2	Black	See drawing or label
2	Yellow	
+ E Volt	Red	See drawing or label
0 Volt	Blue	
0	Brown	See drawing or label
0	Violet	
Case	Shield	

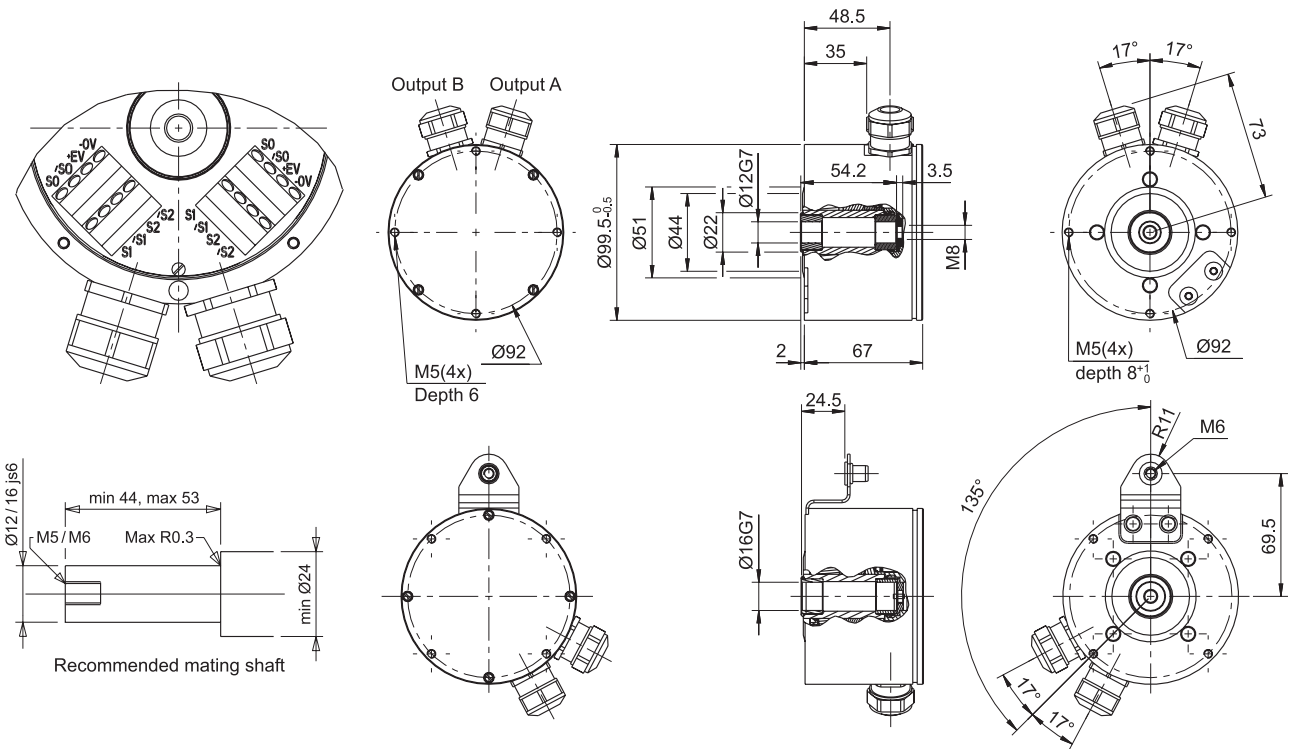

MECHANICAL SPECIFICATION		
Isolated Hollow-shaft	Ø12, 16mm, Stainless steel / PEEK	
Moment of inertia	55 x 10 <sup>-6</sup> kgm <sup>2</sup>	
Load max		
Radial	300N	
Axial	100N	
Speed max	4000 rpm	
Code disc	Standard	Extended temp
Temperature		
Operating	-25°C ... +70°C	-20°C ... +80°C
Storage	-25°C ... +70°C	-25°C ... +80°C
Housing	Aluminum, anodized	
Weight	Approx. 1300g	
Protection class	IP 65 according to IEC 529	
Vibration	<100m/s <sup>2</sup> (50...2000 Hz)	
Shock	<1000m/s <sup>2</sup> (11ms)	
Cable	10x0,25mm <sup>2</sup> twisted pair PVC	

## ORDERING INFORMATION

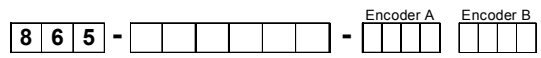

<b>Option</b>	
Mechanical	
0 = Standard	
1 = Torque bracket	
<b>Electrical (A / B)</b>	
0 = Supply 2 x 9-30V, Output 2 x HTL*	
1 = Supply 9-30V / 5V, Output HTL / TTL*	
2 = Supply 2 x 9-30V, Output 2 x HTL**	
3 = Supply 2 x 5V, Output 2 x TTL**	
4 = Supply 9-30V / 5V, Output HTL / TTL**	
5 = Supply 2 x 9-30V, Output HTL / RS-422**	
7 = Supply 2 x 9-30V, Output 2 x RS-422**	
<b>Hollow-shaft</b>	
7 = Ø 12 mm	
8 = Ø 16 mm	
<b>Connection</b>	
4 = 2 x M20 cable gland, radial Ø8-11mm	
5 = 2 x M20 cable gland, radial Ø11-14mm	
3 = 2 x Cable, radial 1.5 m	
9 = 2 x Cable, radial xx m	
<b>Supply voltage</b>	
9 = See options	
<b>Internal use</b>	
1 = Standard 150...2500 ppr	
2 = Standard 2500...5000ppr	
4 = Extended temp 2 x 500, 1000, 1024, 2048, 2500, 3072, 4096, 5000, 6350, 10000ppr	
Other pulserates, contact Leine & Linde for info.	
<b>Line counts</b>	

\* Encoder A with 3 channel High current HTL output, encoder B with 6 channel linedriver output. Only available with cable output.

\*\* Encoder A and B with linedriver output.