

rope length transmitter - type : SL5-X2/GS190/K/01

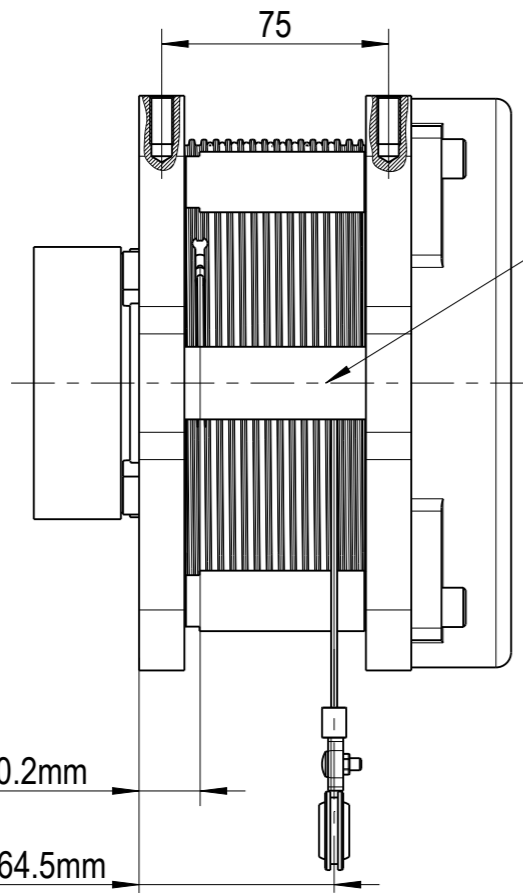
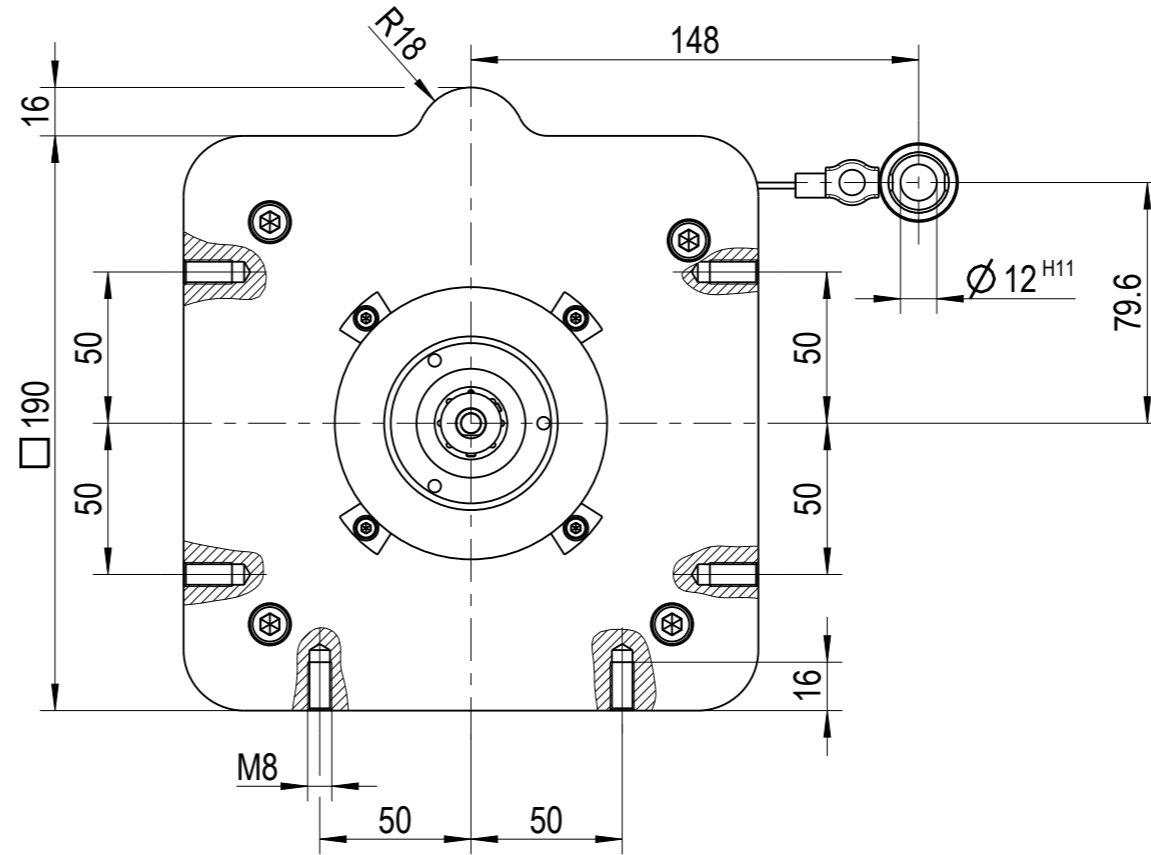
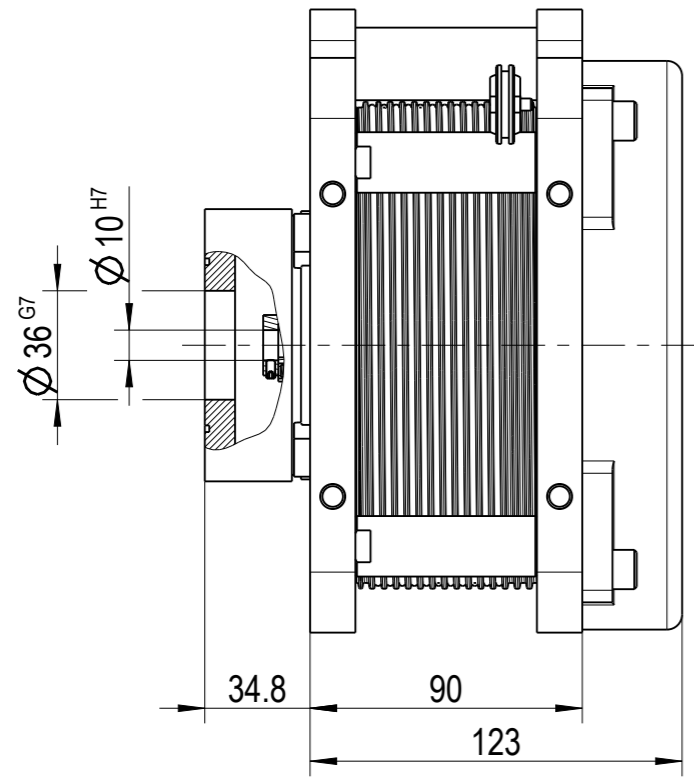

plastic roller

- rope length transmitter with guide groove in the drum
- plastic roller leading rope in the groove
- Ball joint in rope end ring for inclusion of lateral forces
- mounting of an Encoders with clamp flange

measuring range: 0-5m
housing: aluminium anodized
wire-Ø : 2.00mm (1.4401)
drum scope: 500mm
force of the spring: 24...37N
temperature range: -30°C...+70°C
protection class: IP65
weighth: approx.5kg

